

## РУКОВОДСТВО ПО ЭКСПЛУАТАЦИИ

### Ручная гидравлическая тележка DF20/25/30



#### **ПРЕДУПРЕЖДЕНИЕ**

**Не использовать гидравлическую тележку без изучения данного Руководства по эксплуатации.**

#### **ПРИМЕЧАНИЕ:**



**Проверить соответствие данного оборудования типу, указанному на идентификационной табличке**

Version 12/2012

DF-SMS-002-RU

## 10. Каталог запасных частей

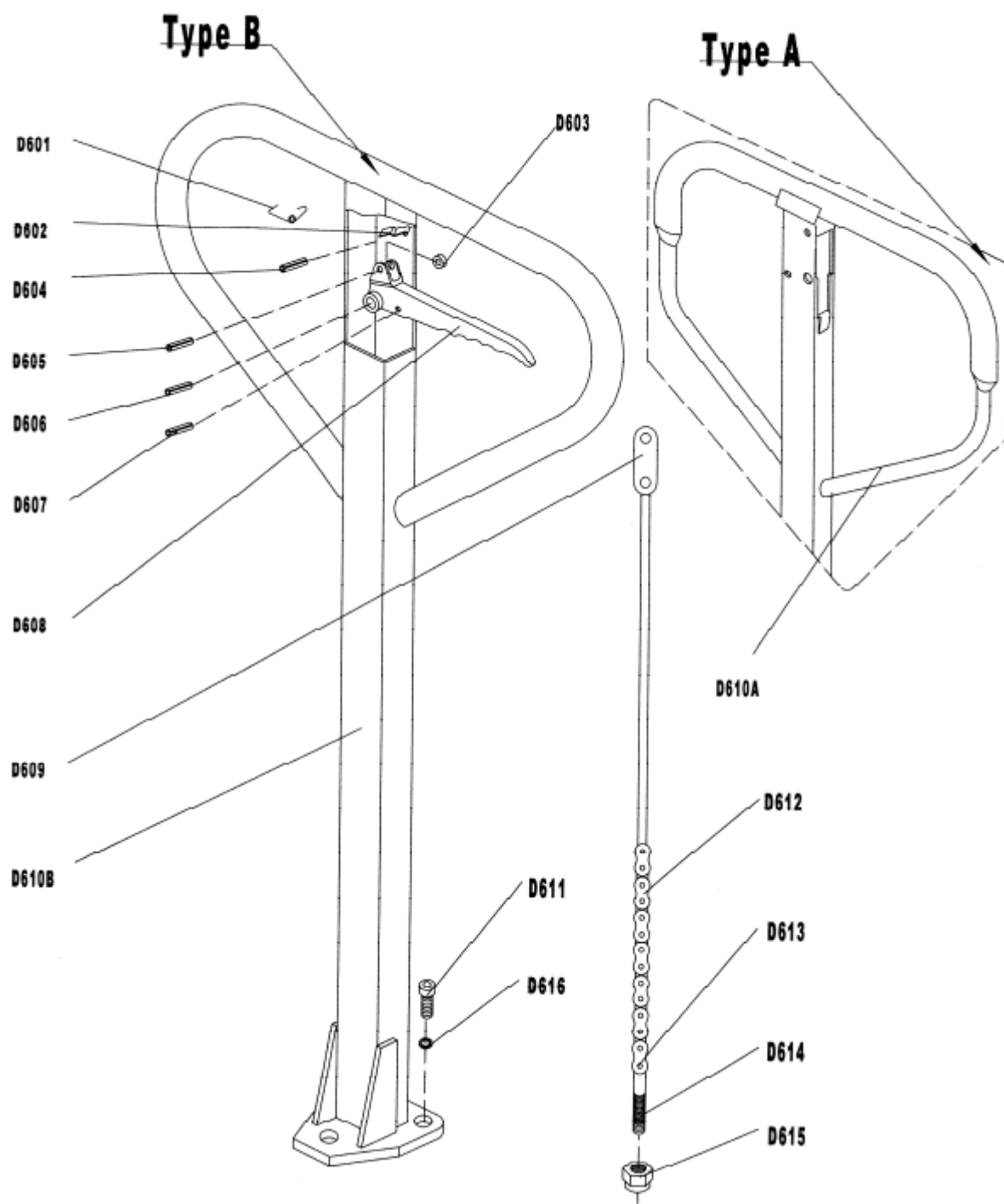

### List of Handle

<b>No.</b>	<b>Description</b>	<b>Qty.</b>	<b>Remark</b>
D601	Spring	1	
D602	Blade Spring	1	
D603	Roller	1	
D604	Elastic Pin	1	
D605	Elastic Pin	1	
D606	Elastic Pin	1	
D607	Elastic Pin	1	
D608	Control Handle	1	
D609	Pull Board	1	
D610B	Handle	1	For Type B
D610A	Handle	1	For Type A
D611	Screw	3	
D612	Chain	1	
D613	Pin	1	
D614	Adjusting Bolt	1	
D615	Adjusting Nut	1	
D616	Elastic Washer	3	

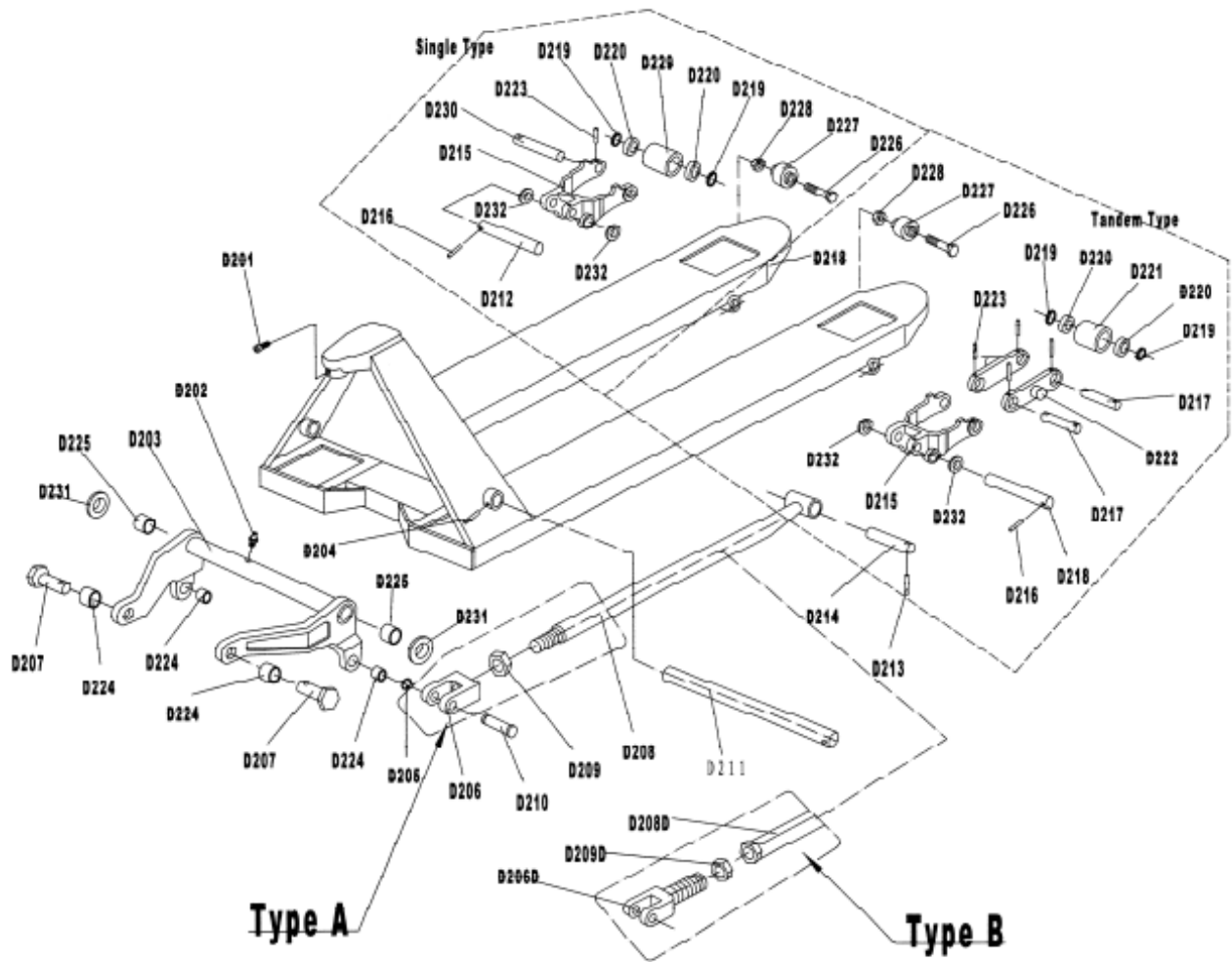

### List of Fork frame

No.	Description	Qty.	Remark	No.	Description	Qty.	Remark
D201	Screw	1		D216	Elastic Pin	2	
D202	Oil - holder	1		D217#	Shaft for Roller	4	
D203	Rock – arm	1		D218	Fork Frame	1	
D204	Elastic Pin	1		D219	Washer	8 or 4	
D205	Retaining Ring	2		D220	Bearing	8 or 4	
D207	Shaft	2	Only for Type A	D221#	Loading Roller	4	
D206	Joint	2		D222#	Linking Plate	4	
D208	Pushing Rod	2		D223	Elastic Pin	8 or 2	
D209	Nut	2	Only for Type B	D224	Bushing	4	
D206D	Joint	2		D225	Bushing	2	
D208D	Pushing Rod	2		D226	Bolt	2	
D209D	Nut	2		D227	Enter Roller	2	
D210	Pin	2		D228	Nut	2	
D211	Shaft	1		D229*	Loading Roller	2	
D212	Shaft	2		D230*	Shaft for Roller	2	
D213	Elastic Pin	2		D231	Washer	2	
D214	Shaft	2		D232	Washer	4	
D215	Frame of Roller	2					

NOTE: # -- For tandem wheel; \* -- For single wheel

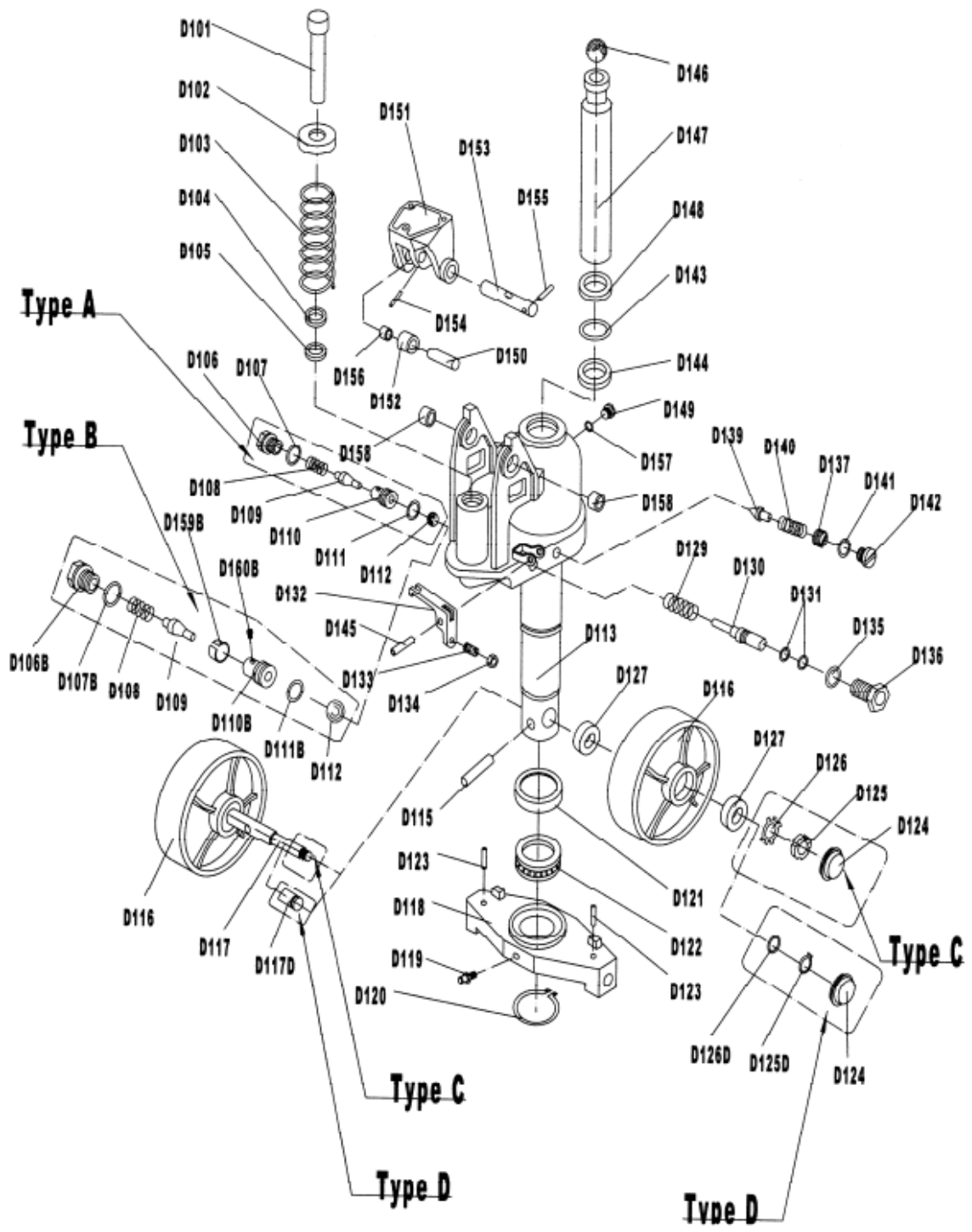

### List of Pump unit

No.	Description	Quantity	Remark
D101	Pump Piston Rod	1	
D102	Washer	1	
D103	Spring	1	
D104	Dust Ring	1	
D105	Y – Seal	1	
D108	Spring	1	
D109	Spindle of Pumping Valve	1	
D112	Steel Ball	1	
D106	Screw	1	Only for Type A
D107	O – Ring	1	
D110	Seat of Pumping Valve	1	
D111	O – Ring	1	
D106B	Screw	1	Only for Type B
D107B	O – Ring	1	
D110B	Seat of Pumping Valve	1	
D111B	O – Ring	1	
D159B	Sleeve	1	
D160B	Screw	1	
D113	Base of Pump	1	
D115	Elastic Pin	1	
D116	Steering Wheel	2	
D118	Thrust Plate	1	
D119	Oil – holder	1	
D120	Retaining Ring	1	
D121	Cover of Bearing	1	
D122	Bearing	1	
D123	Elastic Pin	2	
D124	Dust Cover	2	
D117	Shaft of Steering Wheel	1	
D125	Round Nut	2	
D126	Tab Washer	2	
D117	Shaft of Steering Wheel	1	Only for Type C
D125	Round Nut	2	
D126	Tab Washer	2	
D127	Bearing	4	Only for Type D
D129	Spring	1	
D130	Strike Pin	1	
D131	O – Ring	2	
D132	Lever Plat	1	
D133	Adjusting Screw	1	
D134	Nut	1	
D135	O – Ring	1	

D136	Axle Sleeve	1	
D137	Adjusting Bolt	1	
D139	Spindle of Safety Valve	1	
D140	Spring	1	
D141	O – Ring	1	
D142	Screw	1	
D143	O – Ring	1	
D144	Y – Seal	1	
D145	Elastic Pin	1	
D146	Steel Ball	1	
D147	Piston Rod	1	
D148	Dust Ring	1	
D149	Screw	1	
D150	Shaft	1	
D151	Bracket	1	
D152	Pressure Roller	1	
D153	Shaft	1	
D154	Elastic Pin	1	
D155	Elastic Pin	1	
D156	Bushing	1	
D157	Seal Washer	1	
D158	Bushing	2	

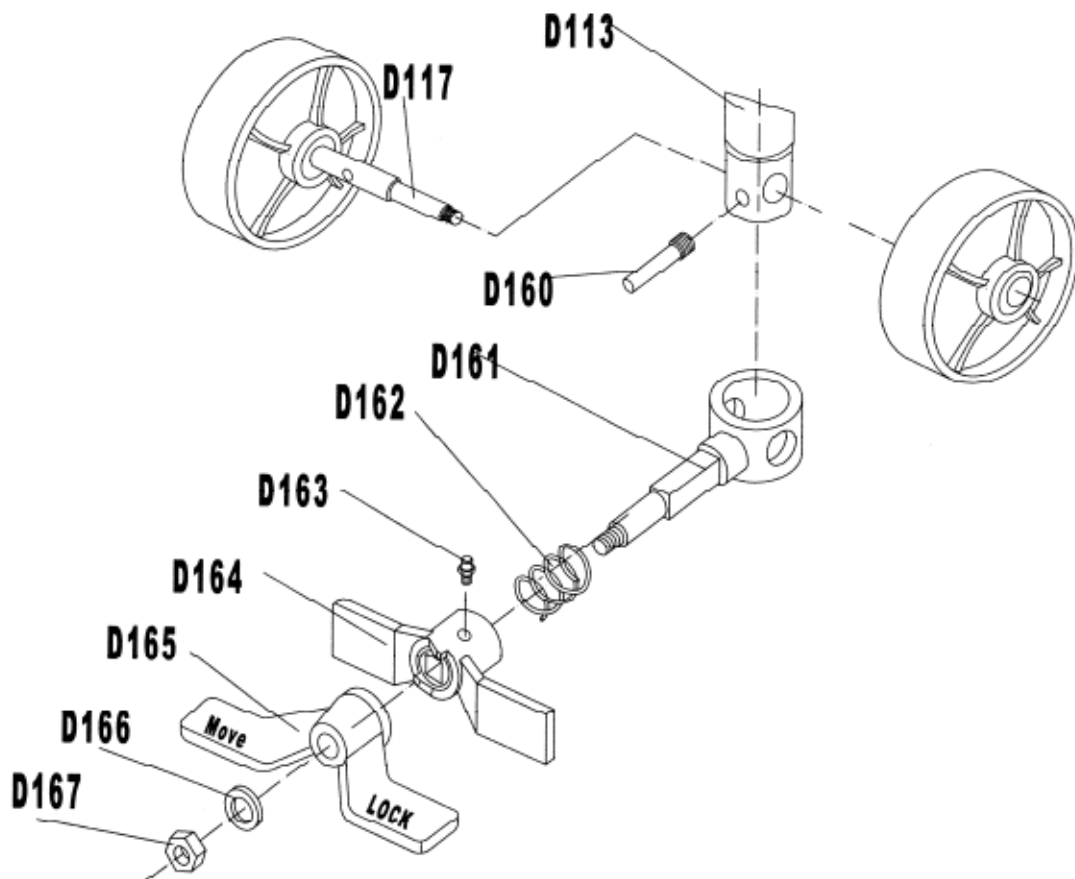

No.	Description	Qty.	No.	Description	Qty.
D117	Shaft of Steering Wheel	1	D163	Oil - Holder	1
D113	Pump Body	1	D164	Brake Plate	1
D160	Pin	1	D165	Pedal	1
D161	Holding Sleeve	1	D166	Washer	1
D162	Spring	1	D167	Nut	1

**NOTE:** The foot brake is a additional part, it may not fixed to your pallet truck. If you need it. you should extra order it.